

The power of plants





Mobilane offices worldwide

- The Netherlands
- Belgium
- United Kingdom
- Germany
- Hungary
- South Africa
- Hong Kong
- United States

“From living rooms, offices, shopping centres and hospitals to car parks and airports, Mobilane’s products have found a multitude of uses worldwide”

Mobilane

In 2001 Mobilane first opened its doors in The Netherlands, as part of the Darthuizer Group - a family owned business with three subsidiaries: Darthuizer Nursery, Oase-Lease, and Mobilane. The Darthuizer Group has been providing quality and innovation for over 80 years. Mobilane is a specialist in developing and marketing instant indoors and outdoors landscaping systems.

Mobilane international

Experience, innovation and passion form the basis for its success, enabling Mobilane to join the global market. Mobilane has offices in the United Kingdom, Germany, Belgium, Hungary, South Africa, Hong Kong and the United States. In collaboration with agents and dealers across more than 35 countries, Mobilane LiveProducts are available and within reach for everyone worldwide.

Mobilane’s Product Development

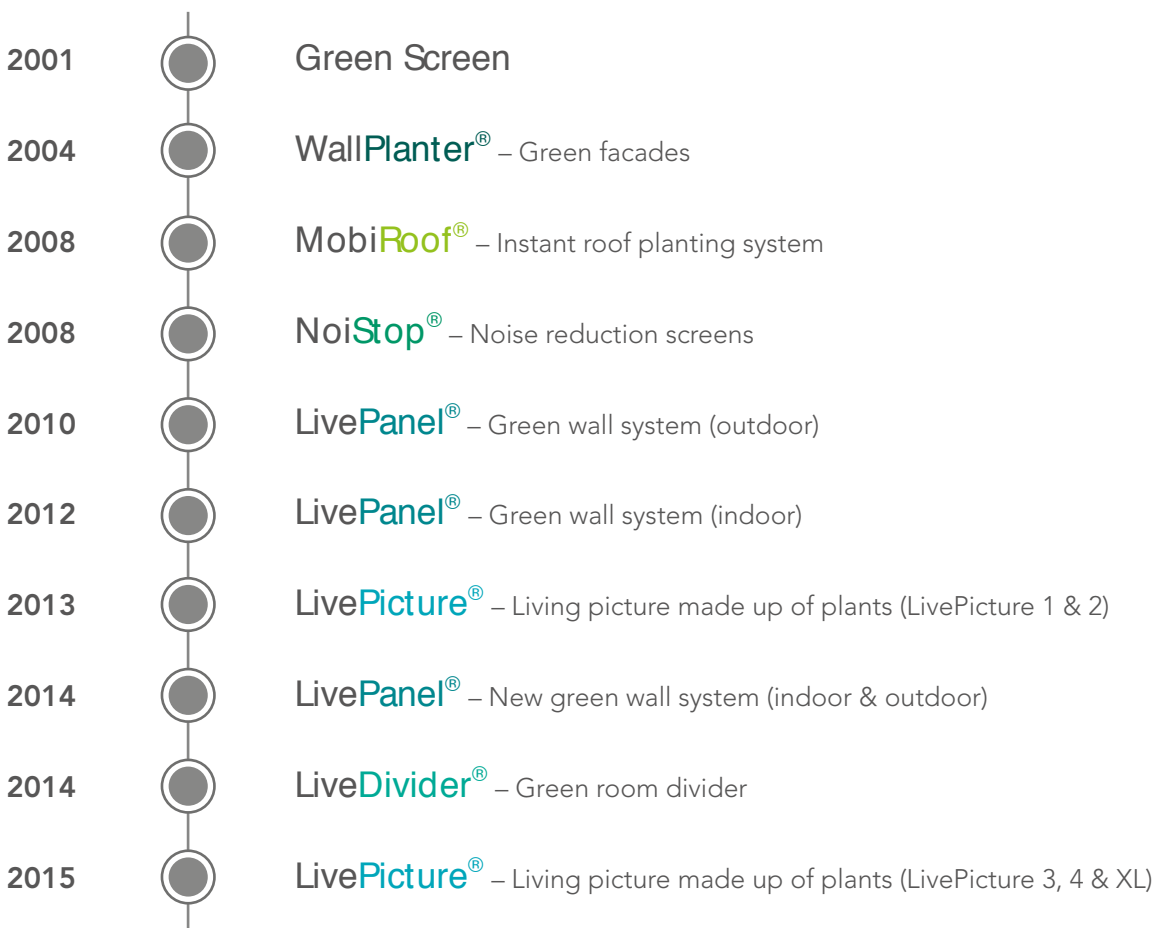

LivePicture® *Living picture made up of plants*

LivePicture embodies innovation, design and landscaping to deliver stunning effects. The frame includes an integrated watering system with reservoir to ensure that the plants are provided with water for four to six weeks. The innovative patented construction requires no electric power. LivePicture can be easily and quickly mounted on any wall using just a few screws.



“Natural green with a modern twist”

Plants make an important contribution to the indoor climate, through their production of oxygen, purification of the air and positive effect on relative humidity. Scientific research has shown that anyone who spends more than four hours per day in a room with plants will find it more pleasant and will be demonstrably more productive.



LivePicture is a stylish and space-saving solution to the use of plants in any interior environment. Rooms with limited space for plant pots will benefit from wall-mounted placement of LivePicture.

LivePicture requires minimal maintenance. It uses a system of plant cassettes that are easily exchangeable. Plants can be changed with ease, for instance to reflect the season or for special occasions such as Christmas or Easter.



In darker rooms, we advise additional daylight lamps to be installed: see LiveSpectrum

LivePicture® *Living picture made up of plants*

LivePicture 1



LivePicture 2



LivePicture® *Living picture made up of plants*

LivePicture 3



LivePicture 4



LivePicture® *Living picture made up of plants*



Specifications of LivePicture 1, 2, 3, 4

Product	Size (w x h x d)	Number of cassettes	Weight (empty)	Volume (litres)
LivePicture 1	72 x 72 x 7 cm	1	12,0 kg	14 ltr
LivePicture 2	112 x 72 x 7 cm	2	16,6 kg	19 ltr
LivePicture 3	152 x 72 x 7 cm	3	21,1 kg	24 ltr
LivePicture 4	192 x 72 x 7 cm	4	25,5 kg	29 ltr

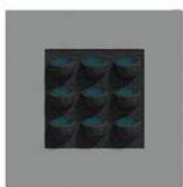

LivePicture 1

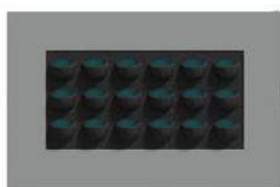

LivePicture 2

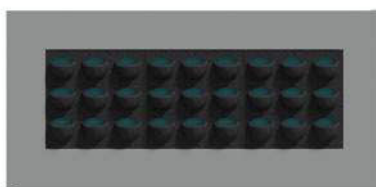

LivePicture 3



LivePicture 4

Available Colours



White



Silver grey



Charcoal

Other (RAL) colours and personalisation with own logo, design or photo are possible on request.

LivePicture XL



LivePicture® *Living picture made up of plants*

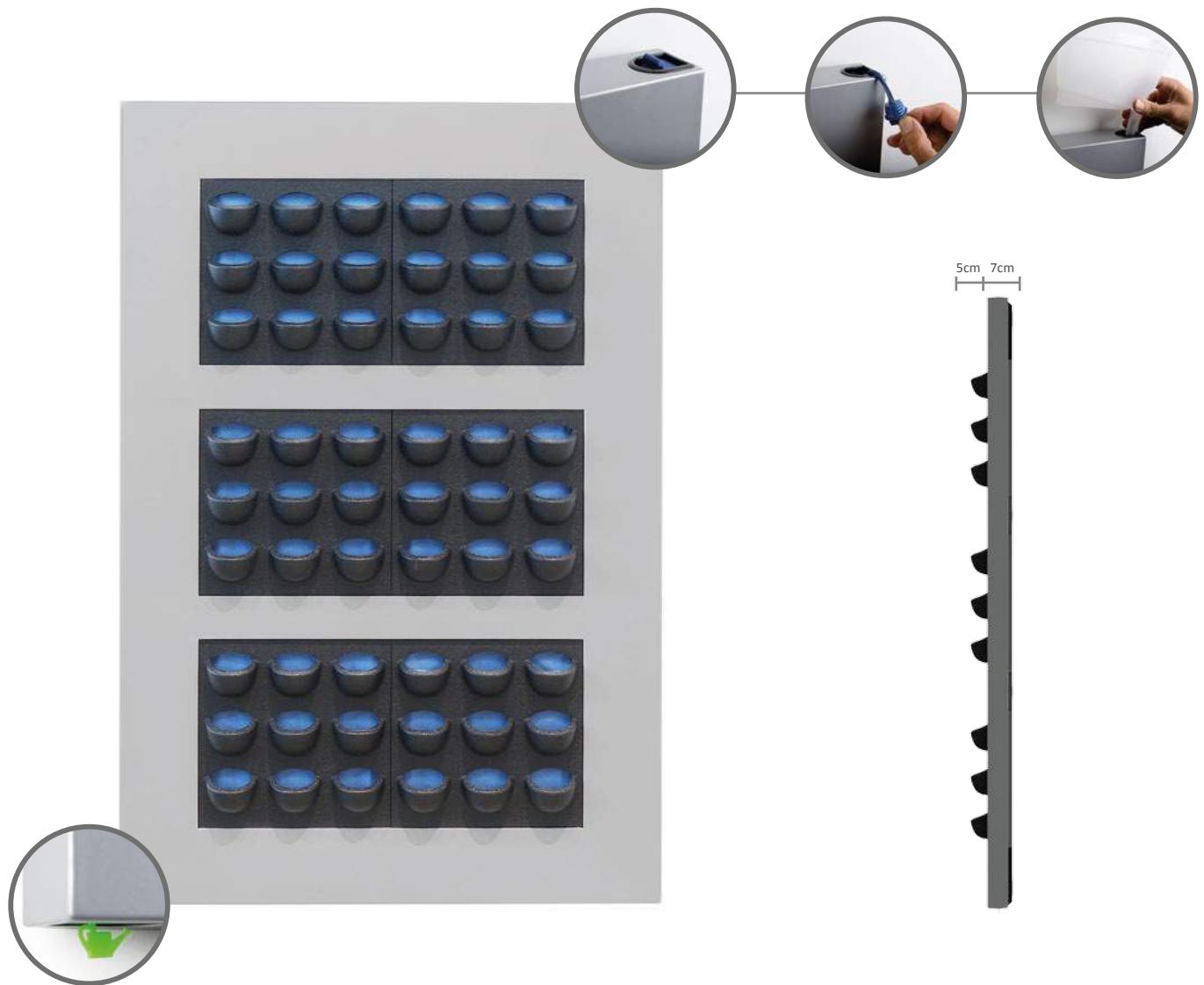

Specifications of LivePicture XL

Product	Size (w x h x d)	Number of cassettes	Weight (empty)	Volume (litres)
LivePicture XL	112 x 170 x 7 cm	6	35 kg	38 ltr

Available Colours



White



Silver grey



Charcoal

Other (RAL) colours and personalisation with own logo, design or photo are possible on request.



Benefits of LivePicture®

- Exchangeable cassettes
- Water supply for 4 to 6 weeks
- Integrated watering system
- No electricity or pump required
- Quick and easy installation
- Smart and silent full and empty indicators
- Can be personalised
- Exchangeable frame
- Modern design
- Improves the room's acoustics
- Contributes to a healthy indoor climate through oxygen production and fine-dust capture

LiveDivider® *The green room divider*

Mobilane's LiveDivider is a designer room divider adorned with plants on both sides. LiveDivider is perfect for dividing up rooms. It creates a more pleasant ambiance, and delivers flexibility in how a room is used. LiveDivider helps create privacy and reduces environmental noise.



“A green solution to more privacy”

LiveDivider consists of a modern metal frame on a sturdy fixed base. The frame has room for six cassettes of plants on either side, 12 cassettes in total. Thanks to the use of exchangeable plant cassettes, the plants can be changed easily and quickly to reflect the season or a special occasion.

The frame incorporates an integrated watering system with reservoir. This ensures that the plants are provided with water for four to six weeks. LiveDivider requires no electricity or batteries.



LiveDivider immediately gives your room a greener and healthier atmosphere. The sustainable landscaping system not only contributes to a healthy indoor climate through the absorption of carbon dioxide and polluting particles, but also creates privacy and a tranquil atmosphere.

LiveDivider[®] *The green room divider*

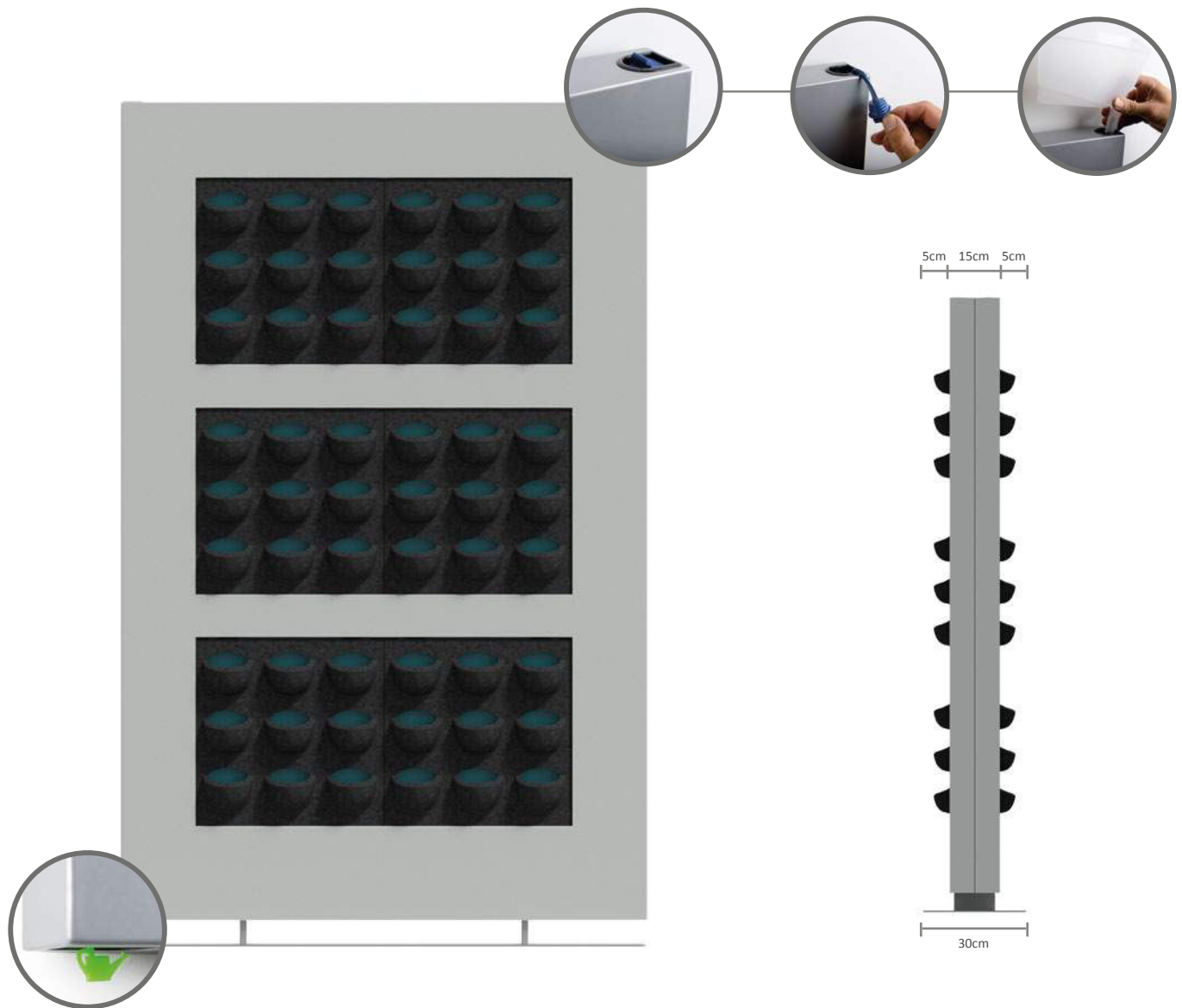

Specifications of LiveDivider

Product	Size (w x h x d)	Number of cassettes	Weight (empty)	Volume (litres)
LiveDivider	112 x 180 x 15 cm	12	128 kg	77 ltr

Available Colours



White



Silver grey

Other (RAL) colours and personalisation with own logo, design or photo are possible on request.



Benefits of LiveDivider®

- Exchangeable cassettes
- Water supply for 4 to 6 weeks
- Integrated watering system
- No electricity or pump required
- Free-standing
- Promotes privacy
- Modern design
- Improves the acoustics in a room
- Contributes to a healthy indoor climate through oxygen production and fine-dust capture

LivePanel[®] *Sustainable plant wall*

Mobilane's LivePanel is an innovative vertical landscaping application that delivers a sustainable 'living wall' system for both indoor and outdoor use. This unique system has been developed for green façades and through over 80 years of landscaping experience. Living walls are becoming very popular, not only in the commercial environment such as offices, shops and public spaces, but also increasingly for residential use.



“LivePanel brings your walls to life”

With LivePanel, you can take the outdoors inside and bring your walls to life. The system easily transforms your wall into an attractive, living surface. LivePanel is a modular living wall system with exchangeable plant cassettes. The cassettes consist of cups in which plants are inserted. Each row of cassettes is placed in a duct profile that also serves as a water reservoir. The plants absorb water from the duct through a capillary system.



LivePanel can be used for various vertical landscaping applications. Let your creativity flow with the design options and plants choices that the system offers. LivePanel can be easily installed on new or existing walls.



In darker rooms, we advise additional daylight lamps to be installed: see LiveSpectrum

LivePanel® *Sustainable plant wall*

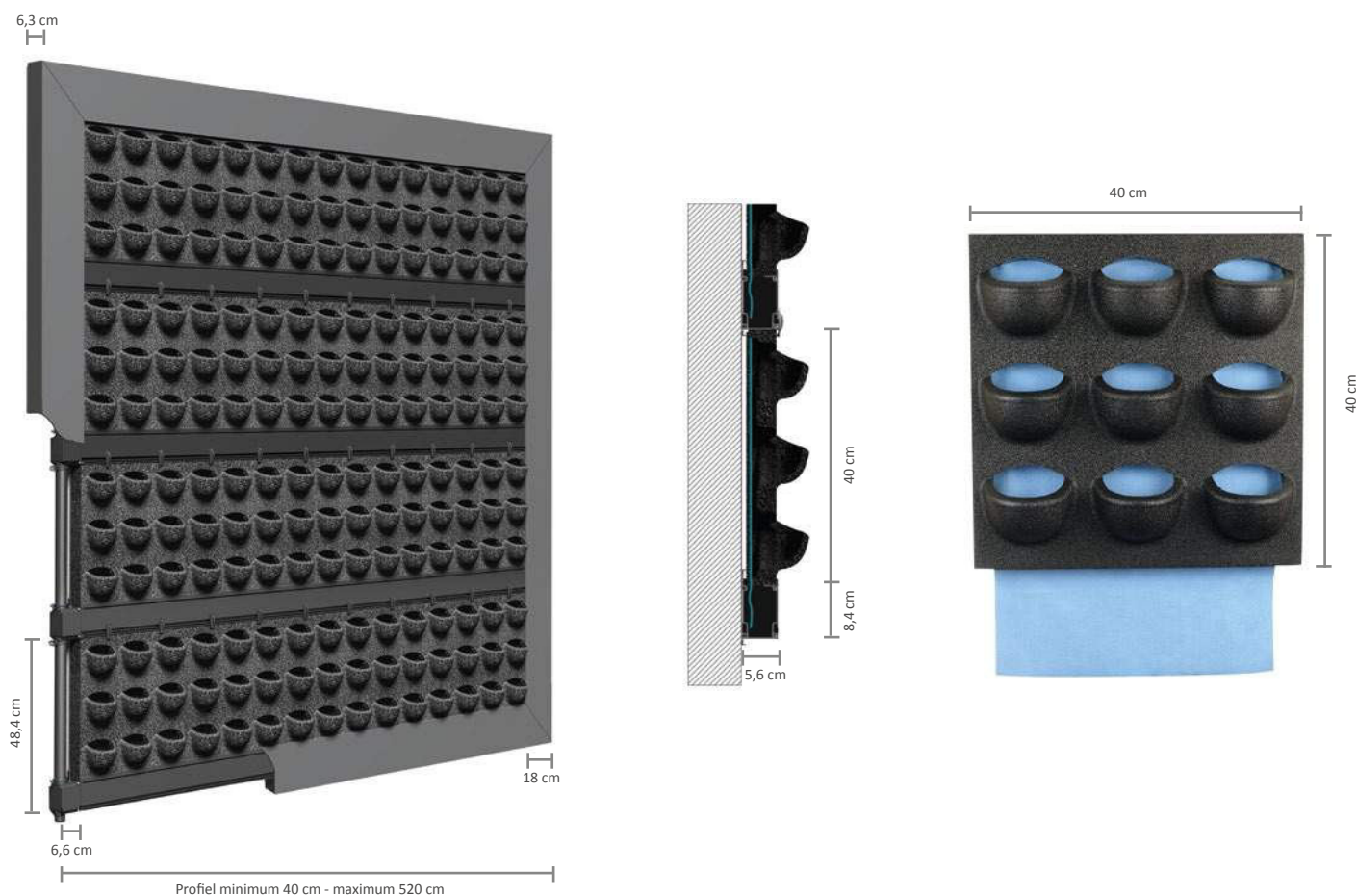

Advice

- A drainage point is compulsory for indoor installations.
- For larger walls, it is advisable to install an automatic irrigation unit. An average water consumption of 5 litres/m² of landscaped surface per week must be taken into account. This depends on local conditions such as the type of plants, surrounding temperature, air-conditioning and light levels.
- Water-resistant foil on the rear wall is recommended for indoor use.

Specifications of LivePanel

Product	Profile length	Number of cassettes	Weight (incl plants and water)
LivePanel	Variable, max. 520 cm	Depending on dimensions of living wall	Max. 40 kg/m ²

Available colours

The optional frame is delivered as standard in blank anodised aluminium. Other colours are possible on request.

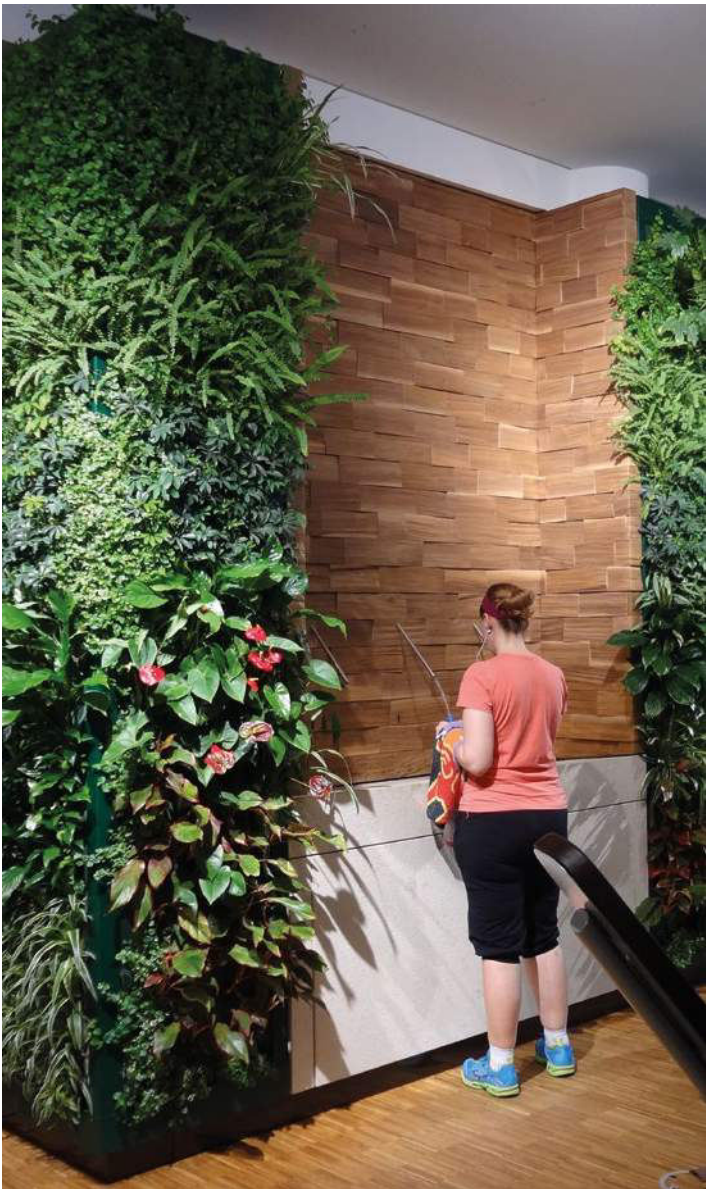

Benefits of LivePanel®

- Exchangeable cassettes
- Easy installation and quick assembly: pre-planted cassettes eliminate soil spillage on location
- Low water consumption
- Modular system
- Indoor and outdoor application
- Very slender construction that takes up little space
- Thermal insulation advantages
- Improves the room's acoustics
- Low maintenance
- Low scent level
- Contributes to a healthy indoor climate through oxygen production and fine-dust capture

LiveSpectrum[®] *LED fixtures concept*

Successful installation of the Mobilane LivePicture and LivePanel products partly depends on the lighting situation on location. Plants normally grow in the sun and use the daylight spectrum. Not all locations where vertical landscaping is desired receive sufficient daylight. That is why Mobilane has developed LiveSpectrum; a light fixture that supports the daylight function.



“LiveSpectrum supports the daylight function”

These LED fixtures have a full spectrum of colour-rendering in the visible portion and are available in different light strengths. The LED fixtures are suitable for integration in ceilings and are provided with an energy-saving LED module with a very long life. The LED fixtures can also be dimmed to ensure the right fine-tuning of desired light strength on the LivePicture and LivePanel products.



Features of LiveSpectrum®

- Light colour available in 3000K (warm white) or 4000K (natural white)
- Excellent colour-rendering for natural colours (CRI 90+)
- LED module is screened off with glass
- Fixture can be rotated and tilted
- Driver can be dimmed per fixture

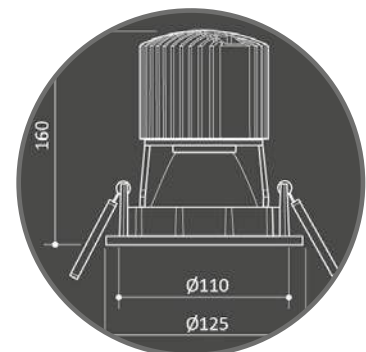

Learn more about our outdoor products as well:

Green Screen



MobiRoof®



WallPlanter®



LivePanel®



NoiStop®



New Zealand distributor: **Metal Art Ltd**
51 Port Road
Lower Hutt 5010

Phone 04 939 6666
Fax 04 939 6696

info@metalart.co.nz
www.metalart.co.nz



mobilane
Building Green